

CHAMBRES POUR OUVRAGES
SOUTERRAINS DE RESEAUX SECS

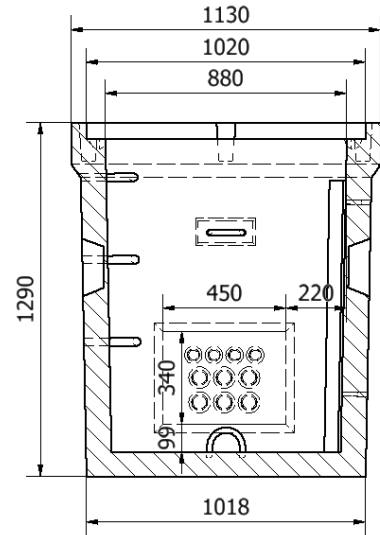
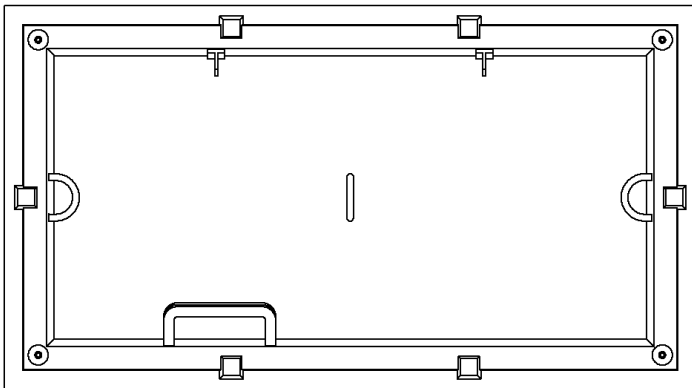
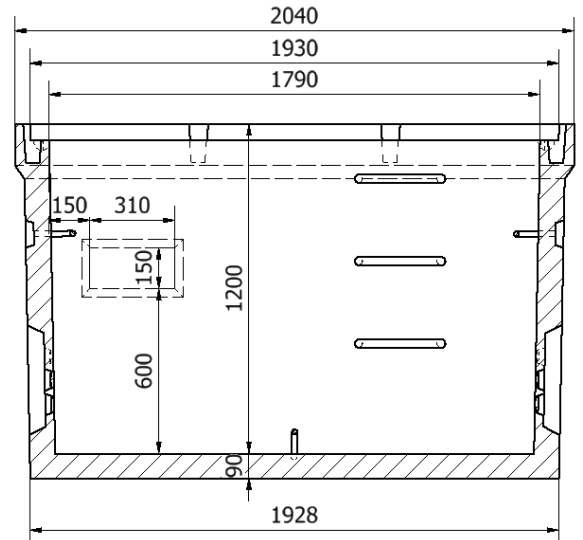

Caractéristiques :

- Poids maximum : 1833 kg
- Longueur minimale d'élingage : 206 cm
- Manutention par 4 ancres de levage 1T3

Usine de fabrication

	Champagné (72)	Chenon (16)	Luçon (85)	Portet (31)
Réf. article		FAB00349		



FT 020 version du 18/06/2024

