

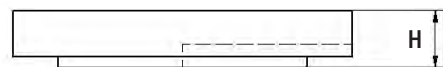

Couvercle

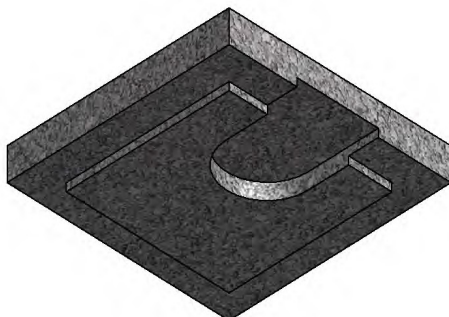

Réhausse

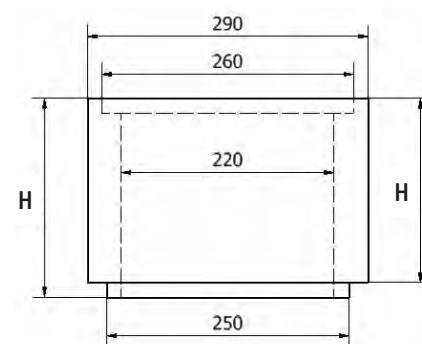
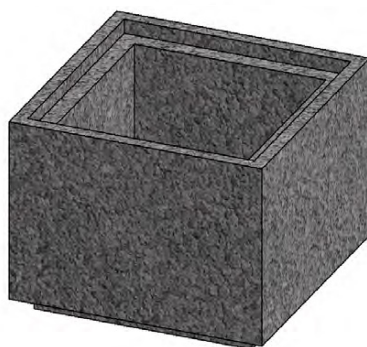

Élément de fond

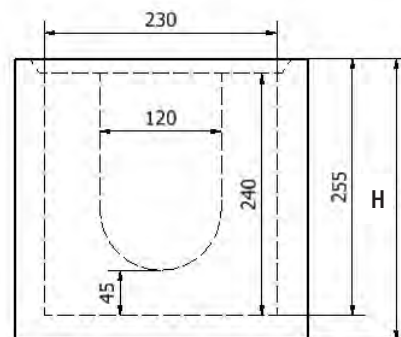
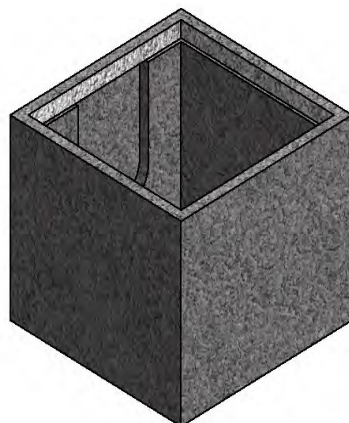

Caractéristiques :

- 2 voiles à briser

	Hauteur (mm)	Réf. article	Poids (kg)
Fond	280	FAB00801	26
Réhausse	200	FAB00996	15
	300	FAB00995	22
Couvercle	50	FAB00364	9

Fabrication usine de Chenon (16)

FT 107 version du 10/06/2024